



MODEL	TUB	SIZE	COLOUR
LUDWA30150	STANDARD	24"	INTEGRATED

FEATURES

Control Type	Top, Electronic
Load Capacity	10 Place Settings
Tub Material	Stainless Steel
Decibel	46 dBA
Number Racks	2 (Upper Adjustable Rack & Lower Rack) + Cutlery Basket
Spray Arms	2 (Top & Bottom)
Number of Programs	5 (Auto Wash, Pots+Pans, Normal Wash, Quick Wash, Rinse+Hold) +
Automatic Door Open	Yes

TECHNICAL

Energy Star Qualified	Yes
Energy consumption, kWh/year	199
Height	32.17-35.04" (817-890 mm)
Width	23.94" (608 mm)
Depth	21.82" (554.3 mm)
Weight	75 lb (34 kg)
Electrical connection:	Power Plug
Electric current supply	120V 60Hz

Dimensions & Installation

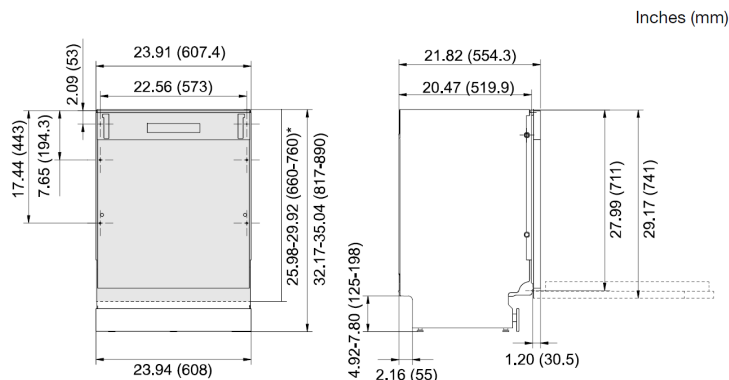

The electrical and water supplies should enter through the area indicated by the shading on the illustration.

